

SUN 2000



SUN 2500



SUN 2500 OB

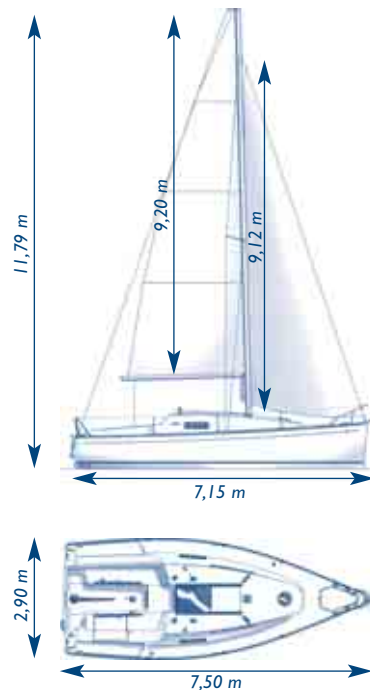
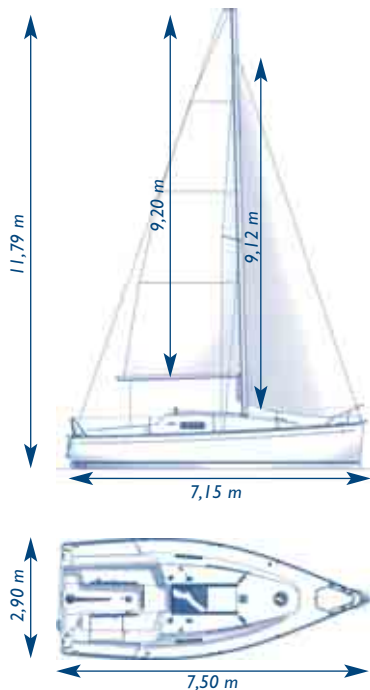
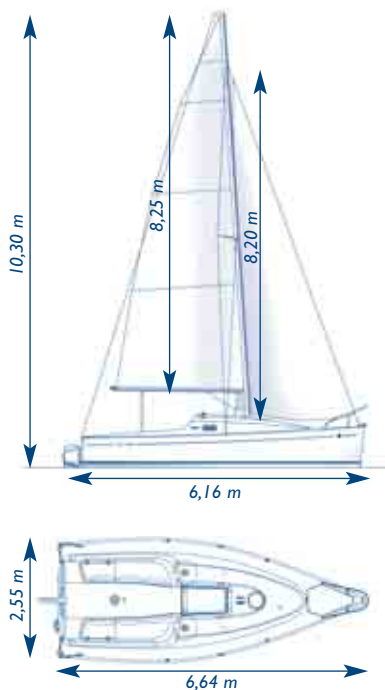

Certification conform with CE regulation.

| | 2000 | 2500 | 2500 OB | |
|--|---|---------------------|---------------------|---------------------|
| Specifications | Overall length | 6,64 m | 7,50 m | 7,50 m |
| | Hull length | 6,20 m | 7,50 m | 7,50 m |
| | Waterline length | 6,16 m | 7,15 m | 7,15 m |
| | Beam | 2,55 m | 2,90 m | 2,90 m |
| | Displacement | 1250 kg | 2240 kg | 2080 kg |
| | Lifting keel epoxy coated fibreglass centreboard that completely retracts into hull, control line lead to line stopper at forward end of the cockpit | 0,30-1,60 m | - | - |
| | Lifting keel epoxy coated fibreglass centreboard that completely retracts into keel box, control line lead to line stopper on coachroof | - | 0,69-1,75 m | 0,69-1,75 m |
| | Lifting keel weight | 360 kg | 670 kg | 670 kg |
| | CE category | C5 | C6 | C6 |
| | Architect/designer | O. Petit | O. Petit | O. Petit |
| | Water capacity flexible water tank located under seating (for SUN 2000 water tank is included in confort version) | 35 L * | 56 L | 56 L |
| | Fuel rotomolded tank located in aft technical space | - | 25 L | - |
| | Holding tank (optional) rotomolded tank located in cockpit locker with valve for overboard discharge via gravity and deck fitting for pump out | - | 50 L | 50 L |
| Fridge fibreglass fridge compartment with vertical access under the chart table | - | 50 L | 50 L | |
| Sails | Classic mainsail polyester sailcloth and 2 reef points with reef lines | 14,1 m ² | 16,6 m ² | 16,6 m ² |
| | Furling genoa 100% polyester sailcloth | 9 m ² | 13,5 m ² | 13,5 m ² |
| | Asymmetrical spinnaker for bowsprit (optional) | 32 m ² | 36 m ² | 36 m ² |
| | Total sail area for standard mast and sails | 23,1 m ² | 30,1 m ² | 30,1 m ² |
| Sail Handling | Winches 2 x Harken 8 winches for genoa and halyards | ■ | - | - |
| | Winches 2 x Harken 16.1 self-tailing winches for genoa and halyards | - | ■ | ■ |
| | Genoa tracks adjustable lead cars and Harken turning blocks | - | ■ | ■ |
| | Winch handle | ■ | ■ | ■ |
| | Line jammers Spinlock, on coachroof | - | ■ | ■ |
| | Mainsheet block and tackle attached to padeye in cockpit for easy use and can be removed when in port | ■ | ■ | ■ |
| Asymmetrical spinnaker gear with bowsprit halyard, 2 sheets, tack line lead forward on deck, 4 blocks | □ | □ | □ | |

■ Standard □ Option - Not available * Version confort

| | | 2000 | 2500 | 2500 OB |
|--|--|------|-------|------------|
| Mast and Rigging | Classic mast aluminium with single spreaders, deck-stepped | ■ | ■ | ■ |
| | Mast stepping kit hinged mast step and support bar for easy mast stepping | □ | - | - |
| | Standing rigging stainless steel wire | ■ | ■ | ■ |
| | Backstay adjustable via block and tackle system | ■ | ■ | ■ |
| | Genoa furler Facnor® furler with attachment to stemhead fitting and furling line lead aft to roof winch | ■ | ■ | ■ |
| | Running rigging polyester mainsail halyard, genoa halyard, mainsheet, genoa sheets | ■ | ■ | ■ |
| | Boom topping lift | - | ■ | ■ |
| | Boom vang block and tackle system | ■ | ■ | ■ |
| | Masthead light tri-colour running light | - | ■ | ■ |
| Windex 15 wind indicator for masthead | - | □ | □ | |
| Cockpit & Deck Storage | Teak grabrails along cockpit seating | ■ | ■ | ■ |
| | Cockpit locker 1 large cockpit locker to starboard under bench seat | - | ■ | ■ |
| | Cockpit lockers 2 lockers under bench seats | ■ | - | - |
| | Cockpit table removable on aluminium leg – same table as saloon table | * | ■ | ■ |
| | Tiller varnished wood tiller with extension handle, folds out of the way to keep cockpit clear | ■ | ■ | ■ |
| | Retractable rudder mounted on transom | ■ | - | - |
| | Twin rudders with full-length stainless steel stock and protective caps for beaching | - | ■ | ■ |
| | Compass bulkhead-mounted | - | ■ | ■ |
| | Transom with self-bailing drains | ■ | ■ | ■ |
| | Outboard motor bracket | ■ | - | ■ |
| | Instrumentation dedicated space at forward end of the cockpit | - | ■ | ■ |
| | Engine controls throttle | - | ■ | - |
| | Swim ladder folding ladder mounted on transom | ■ | ■ | ■ |
| Winch handle holder | ■ | ■ | ■ | |
| Anchor locker forward, room for anchor and tackle | ■ | ■ | ■ | |
| Deck | Bow and stern pulpits stainless steel | ■ | ■ | ■ |
| | Anchor roller single roller | ■ | ■ | ■ |
| | Lifelines single level of stainless steel lifelines with PVC coating, stainless steel stanchions | ■ | ■ | ■ |
| | Toerail aluminium toerail with teak insert | ■ | ■ | ■ |
| | Cleats 4 x mooring cleats forward and aft | ■ | ■ | ■ |
| | Anchoring kit fluke anchor 10kg with 15 meters of 8mm chain and 23 meters of 14mm line | □ | - | - |
| | Anchoring kit fluke anchor 12kg with 18 meters of 8mm chain and 27 meters of 14mm line | - | □ | □ |
| | Mooring kit 6 fenders and 3 docklines | □ | □ | □ |
| | Chainplates for legs attachment point for support legs during used for drying out | - | □ | □ |
| Teak rails along companionway entrance | ■ | ■ | ■ | |
| Construction | Deck in beige gelcoat Prisma Process® injected deck, discontinuous balsa block coring | ■ | - | - |
| | Deck in beige gelcoat hand-laid fibreglass deck, discontinuous balsa block coring, interior fibreglass deck counter mould | - | ■ | ■ |
| | Hull in beige gelcoat solid, hand-laid fibreglass | ■ | ■ | ■ |
| | Hull in blue gelcoat solid, hand-laid fibreglass | - | □ | □ |
| | Structure inner fibreglass grid | ■ | ■ | ■ |
| Electrical | Flush mounted chromed brass ceiling lights | * | ■ | ■ |
| | 12v alternator output | - | 35 A | - |
| | Engine start battery capacity | - | 70 Ah | - |
| | Battery 70 Ah for domestic bank | * | - | - |
| | Battery 70 Ah for domestic bank with 230v shore power inlet, differential breaker, one 230v plug at nav station + 12 A battery charger | - | □ | □ |
| | Battery switches for standard battery and optional battery when ordered | - | ■ | ■ |
| Plumbing | Electrical panel with 12v fuses and switches | - | ■ | ■ |
| | Hand pump with sink in saloon | * | - | - |
| | Foot pump with stainless sink in galley | - | ■ | ■ |
| | Hand pump with fibreglass sink in head compartment | - | ■ | ■ |
| | Chemical toilet | □ | ■ | ■ |
| Manual pump marine toilet | - | □ | □ | |
| Engine | Yanmar IGM10 9 HP, 6.7Kw with heat exchanger, latest generation of environmentally friendly engines | - | ■ | - |
| | Recommended outboard size (not available from Jeanneau) | 6 CV | - | 9 CV |
| | Soundproofed engine compartment with engine access via opening compartment under stairs | - | ■ | - |
| | Stainless steel propeller shaft 25mm diameter | - | ■ | - |
| | Fuel/water separator | - | ■ | - |
| | Muffler, air ventilation and stainless steel exhaust fitting aft | - | ■ | - |
| | Fixed 2-blade bronze propeller | - | ■ | - |
| Folding 2-blade bronze propeller, Flex-a-fold® | - | □ | - | |

■ Standard □ Option - Not available * Version confort

| | | 2000 | 2500 | 2500 OB |
|-------------------------------|--|---------------------|---------------------|---------------------|
| Interior features and options | Moabi laminated panels with solid moabi trim around galley, companionway and cabinetry, finished in satin UV stabilised varnish | ■ | ■ | ■ |
| | Laminate floorboards | * | ■ | ■ |
| | Forward V-berth | 1,90 m / 1,40 m | 2 x 2,60 m / 0,60 m | 2 x 2,60 m / 0,60 m |
| | Twin berths with foam mattresses | ■ | ■ | ■ |
| | Storage lockers under berth | ■ | ■ | ■ |
| | Vinyl lining on hull | ■ | ■ | ■ |
| | Lateral wood shelving along hull | - | ■ | ■ |
| | Aft berth | 2 x 2,00 m / 0,88 m | 1,97 m / 1,43 m | 1,97 m / 1,43 m |
| | Double berth with foam mattress and storage cabinetry | - | ■ | ■ |
| | 2 x single quarter berths to either side of the cockpit | ■ | - | - |
| | Vinyl lining on hull with lateral wood shelf | ■ | ■ | ■ |
| | Head compartment accessible from saloon with sink and storage cabinet | ■ | ■ | - |
| | Navigation station with general electrical panel, storage in the desk and access to fridge box | - | ■ | ■ |
| | 12v fridge with compressor under saloon seating and evaporator in insulated box under chart table | - | □ | □ |
| | CD / radio in saloon with 2 speakers in saloon | - | □ | □ |
| | Opening roof ports on each side of coachroof for ventilation | ■ | ■ | ■ |
| | Opening deck hatc circular, forward-facing | * | ■ | ■ |
| | Saloon with seating area and storage | ■ | ■ | ■ |
| | Removable wood saloon table that can also be used as a cockpit table | * | ■ | ■ |
| | Stainless steel compression post | ■ | ■ | ■ |
| | Filler cushion to turn forward seating into a double berth | ■ | □ | □ |
| | Companionway with removable starboard entry door | ■ | ■ | ■ |
| | Fibreglass hatch cover | ■ | - | - |
| | Sliding plexiglass companionway hatch | - | ■ | ■ |
| | Fibreglass compartment with wood steps and housing the engine panel, ignition and pull stop | - | ■ | - |
| | Fibreglass compartment with wood steps and houses storage compartments | - | - | ■ |
| | Galley to port with laminate countertop | - | ■ | ■ |
| | 1-burner stove | * | ■ | ■ |
| | Portable icebox 25 L | □ | - | - |
| | Bottle storage | - | ■ | ■ |
| | cabinets for storage and dishes | - | ■ | ■ |
| | Headroom | | | |
| Companionway | 1,28 m | 1,60 m | 1,60 m | |
| Saloon | 1,28 m | 1,55 m | 1,55 m | |
| Galley | 1,22 m | 1,60 m | 1,60 m | |
| Head compartment | - | 1,65 m | 1,65 m | |

■ Standard □ Option - Not available * Version confort



JEANNEAU préconise **IGOL**

